

Drawing #: 60212-P

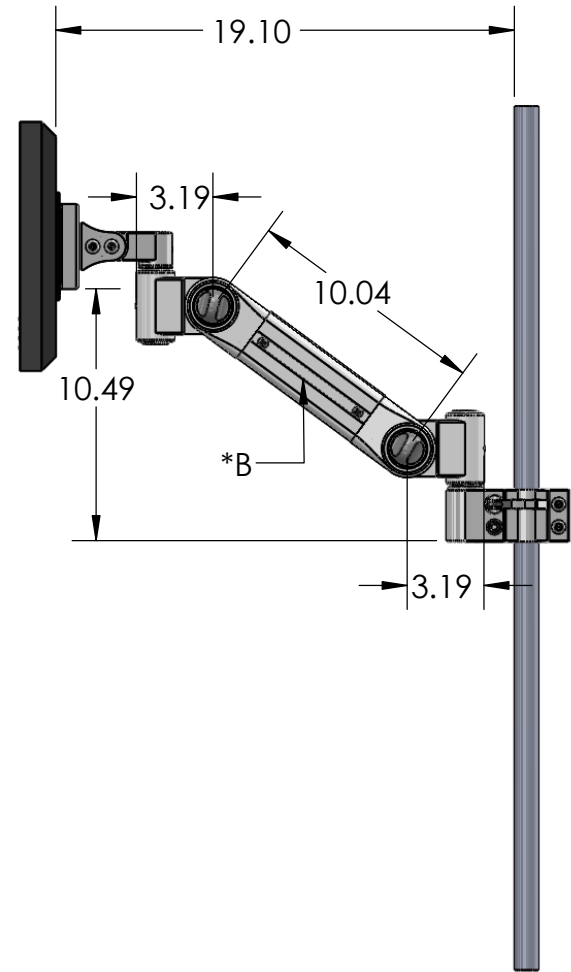
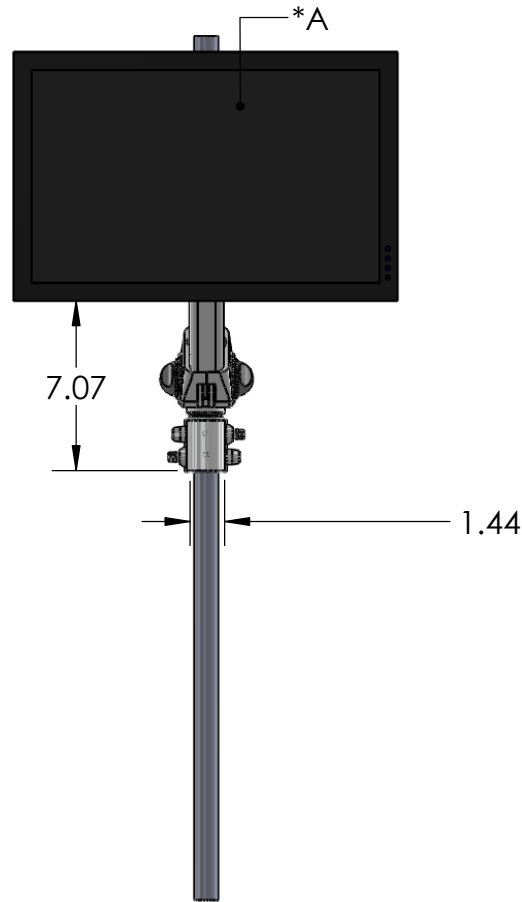
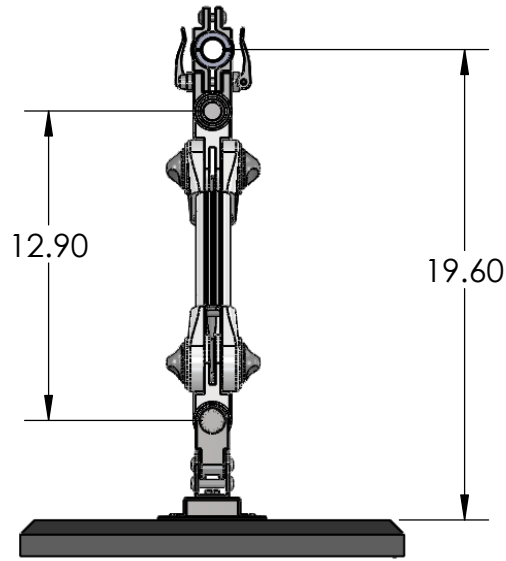

\*A: Monitor used for drawing purposes only. Monitor Provided by the customer.  
 \*B: Arm is height adjustable from vertical to horizontal. some dimensions may vary.

**PROPRIETARY AND CONFIDENTIAL**  
 THE INFORMATION CONTAINED IN THIS DRAWING IS THE SOLE PROPERTY OF CUSTOM PRODUCTS AND SERVICES. ANY REPRODUCTION IN PART OR AS A WHOLE WITHOUT THE WRITTEN PERMISSION OF CUSTOM PRODUCTS AND SERVICES IS PROHIBITED.

		UNLESS OTHERWISE SPECIFIED:	NAME	DATE		
		DIMENSIONS ARE IN INCHES	DRAWN	7/7/15	TITLE:	
		TOLERANCES:	CHECKED			
		FRACTIONAL ±	ENG APPR.			
		ANGULAR: MACH ± BEND ±	MFG APPR.			
		TWO PLACE DECIMAL ±	Q.A.			
		THREE PLACE DECIMAL ±	COMMENTS:			
		INTERPRET GEOMETRIC TOLERANCING PER:			SIZE	DWG. NO.
		MATERIAL			<b>A</b>	60212-P
NEXT ASSY	USED ON	FINISH			REV	
APPLICATION		DO NOT SCALE DRAWING			SCALE:	WEIGHT:
					SHEET 1 OF 2	